

Caring Communities
Presents the Largest &
Most Anticipated
Event in the
Region!



**Coming to
The Nation's Capital Region
and Western Maryland**

Featuring a Full Day of Disability
& Senior Related
Products, Equipment,
Services & Resources

**ATTENTION
EXHIBITORS!**

Your Passport to Family
Caregivers, Individuals
with Disabilities, Seniors
Healthcare and Education
Professionals.



NATION'S CAPITAL REGION
Samuel Riggs IV Alumni Center, University of Maryland, College Park, MD
MAY 3, 2025

WESTERN MARYLAND REGION
Clarion Inn Frederick Event Center, Frederick, MD
MAY 17, 2025

Advantages The World of Possibilities

Here are ways our targeted effective marketing campaign will reach the Audience you need:

LOCAL SPONSORSHIPS / AGENCY PROMOTION OF EXPOS

Promotion of our events will include direct mailings, newsletter articles in Local, Statewide and National newsletters, and announcements on websites, all through collaborations with agencies and organizations that serve the disabled and senior community and potential buyers.

FREE COUPONS

Thousands and thousands of FREE passes will be distributed to Expo vendors, direct service provider organizations, professional organizations, support groups, state and local agencies, the disabilities community, Seniors, their families and MORE!

EMAIL CAMPAIGN

A team will be appointed to contact service organizations, educators, allied healthcare professionals, individuals, family members, caregivers, etc.

STREET BANNERS & ROAD SIGNS

As the dates draw near, we want MAXIMUM public exposure!

WEBSITE MARKETING

Our web site, www.caringcommunities.org, features a World of Possibilities Expo link, highlighting information on the Expo exhibitors and offers a Free Coupon download. The website link will be included on all promotional material and over 100 other websites.

MEDIA EXPOSURE

Advertisements will be funneled through social media and search engine placements, as well as newsletters and local event websites. We will also place announcements on local cable television and radio stations to advertise the event offering Free coupons. Frequent submissions of press releases will be published before and after the event.

NON-PROFIT NETWORKING

Non-profit organizations routinely network for the benefit of the Disability & Senior Community. Speaker Bureaus, Expo Advisory Committees comprised of top State agency leaders, interagency trainings, and listserves provide many promotional opportunities that will be utilized.



Produced & Managed by
Caring Communities
Visit www.caringcommunities.org

Why Choose... **World of Possibilities Expos?**

Best Locations

Individuals from Maryland, Washington, DC, Northern Virginia and the surrounding states will have easy access to this premier event conveniently located in the Baltimore/Washington corridor. The hub of the country, where many major disability organization's National headquarters are based, has never been served this way before. According to a recent report by the CDC, one in 4 U.S. adults – 61 million Americans – have a disability that impacts major life activities.

One-Stop Shopping

Individuals with disabilities, seniors, family caregivers and the professionals who serve them have often said that they need one-stop shopping opportunities!

Exclusive Exhibitor Benefits

- Very reasonable exhibition space rates, starting at \$445 !
- Your company will be listed FREE on our website promoting the Expos.
- FREE Expo passes for your customers
- FREE listing and company description in Expo program

Family-Focused Attractions

The Expo floor will host a wide array of the latest products and services representing assistive and adaptive technology, automotive, mobility, durable medical equipment, personal care, travel, computer, books and many other industries. Many incentives to increase Expo participation including:

- Informative workshops for both direct service providers, consumers with disabilities & Family Caregivers
- Interactive demonstrations
- Celebrity book signings
- Dignitaries' visits
- And more!!

We Know Our Disabilities Community

World of Possibilities Expos are presented to the public by Caring Communities, Inc., a nonprofit 501(c)3 disability organization. Caring Communities, Inc. is a well known and highly respected entity in the disability arena. Caring Communities, Inc. serves individuals with disabilities and their families in Maryland, DC, and Virginia and knows the region! With key staff members having over twenty years of experience, many relationships have been forged to have greater collaboration and partnership to promote this event.



World of Possibilities Expos 2025

Presented by Caring Communities, Inc.



The Formula for Successful Expos

Thank you for your interest in our World of Possibilities Expos. We have received an overwhelming response over the past 20 years! We are confident that exhibitors will experience great success and that attendees will find our Expo extremely meaningful.

WHO WE ARE

A nonprofit 501(c)3 organization with thorough knowledge of and experience in the local disabilities community, we have collaborated with hundreds of local agencies and organizations in MD, DC and VA. Expo proceeds will support families of children with disabilities. Over 50 organizations have signed endorsement forms agreeing to support our Expo, including several national organizations, and many more are signing on all the time.

In addition, the Expo has it's own Advisory Panel composed of leaders in the disability services field. Because we have a vested interest and vast experience in the disabilities community, we understand how to properly serve it.

EXPO MANAGEMENT

The Caring Communities has successfully run World of Possibilities Expos since 2004 for families in Maryland, Northern Virginia, and DC areas.

TARGETED MARKETING

Marketing of this event will be done locally and nationally. Announcements will be made through Statewide and National disability newsletters, e-mail campaign, social media, search engine advertising, thousands of FREE expo passes distributed through local supermarkets, support groups, and websites.

In addition, our marketing plan includes road signs in each area, radio announcements, TV/cable coverage all offering **FREE coupons** as well as frequent submission of press releases. In addition, both of our Expos will be actively promoted throughout Expo area and surrounding states.

WEB EXPOSURE

Our web site, www.caringcommunities.org, features a World of Possibilities Expo link, highlighting information on the Expo exhibitors and sponsors. The Expo website worldofpossibilities.org will be included on all promotional material and over 100 other websites.

ONE-STOP SHOPPING

These Expos will host a wide array of the latest products and services representing assistive and adaptive technology, automotive, mobility, durable medical equipment, personal care, travel, computer, books and many other industries. Many additional incentives will be offered to increase Expo participation including:

- Informative workshops for both direct service providers and consumers with disabilities
- Interactive demonstrations
- A full day of entertainment for everyone!
- Dignitaries' visits and more!

FEATURES

Exhibitors from all around the country, local support groups, advocacy groups, self advocacy groups and other resources will be available at the Expo. We will offer personal care assistants, sign language interpreters, wheelchair rentals and FREE wheel chair repair! Loads of family fun too!

EXHIBITOR BENEFITS

- Your company will be listed FREE on our website promoting the Expo.
- FREE listing and company description in Expo program.

We invite you to join us at these world-class events in the Nation's Capital Region and Western Maryland Region..

Caring Communities

World of Possibilities Expos 2025

Nation's Capital Region, College Park, MD



Exhibitor Name (Note: Name listed here will be used for your booth sign, badges, website and directory listings)

Contact _____ Title _____

Mailing Address _____

City _____ State _____ Zip _____

Billing Name & Address (If different) _____

Phone _____ Fax _____

Email _____ Website _____

APPROVAL
(FOR OFFICE USE ONLY)

Date _____

Booth # _____

EXHIBIT SPACE PRICING: (All spaces except Cat. G include 6' table & two chairs, exhibit sign)
DOUBLE YOUR EXPOSURE: Multiple Spaces or Multiple Expos Deduct 5%

Expo	Standard Space F Spaces	Promotional Partner Package*	Category G Spaces Incl. 28" high top	Premium Space A, B, C and D Spaces
Nation's Capital Region May 3, 2025	<input type="checkbox"/> \$595	Call for more information	\$295 Call for Availability	<input type="checkbox"/> \$645

***Promotional Partner Package:** Contingent upon approval as a Promotional Partner with signed Partnership Agreement (Promotional Partners agree to help promote the Expo to their contacts within the disabilities community).

† **Electric** MAY NOT be available unless you reserve it in advance. **ADD ELECTRIC** \$30

Total _____

Payment Options: (Please Check One)

TERMS: A 33% deposit must accompany this contract. Booth space cannot be reserved without a deposit. Balance is due 60 days prior to the start of each event. Failure to pay the balance when due may result in cancellation, relocation, or forfeiture.

Check: Make Check Payable To: **Caring Communities, Inc.**

Credit Card: VISA MC AMEX DISC
 Card # _____

Name on Card _____ Exp. Date _____

Security Code # (on back of card) _____

Billing address of credit card: Same as above

Different Billing Address: _____

Pay Online: Please provide me a payment link.

Billing email: _____

SPACE PREFERENCES

I would prefer **NOT** to be located near the following companies:

Describe your display _____

FREE 25-Word Company Description for Expo Program Guide:

Return Form To:

CARING COMMUNITIES
 1341 West Liberty Rd.
 Sykesville, Maryland 21784
 accounts@caringcommunities.org

Office: 410-549-5707
 Sales: 443-622-5983
 Fax: 410-549-6467

The undersigned ("Exhibitor"), as a duly authorized representative, enters into an agreement with Caring Communities, the Exposition Manager, to rent exhibit space at the expositions indicated above. Space will be assigned by Caring Communities at its sole discretion and may be changed for the benefit of the exposition. Exhibitor agrees to abide by official Exhibitor Regulations (see other side of this agreement) and by the following **Cancellation Policy:** If Exhibitor desires to cancel all or part of the exhibit space, the Exhibitor acknowledges that the **Producer** would be harmed and suffer loss, but that the precise value of that harm would be difficult to calculate. Therefore any payment required herein shall be considered reasonable pre-agreed liquidated damages and not a penalty. **All cancellations, withdrawals, or reductions in space by Exhibitor must be in**

writing, by certified mail, return receipt requested. Requests for cancellation made up to 90 days prior to the start of the event are subject to a fee equal to 33% of the total booth space fee; from 89 days or less prior to the start of the event, Exhibitor is subject to a fee equal to 100% of the total booth space fee. If Exhibitor defaults in payment, Exhibitor is liable to Caring Communities for collection costs, including reasonable attorney's fees. Caring Communities reserves the right to accept or reject exhibitor space applications and to cancel any previously accepted exhibitor space applications or contracts, at any time in its sole discretion, for any reason, or no reason, without liability to the applicant, exhibitor or any other third party. This contract is not valid until said contract is fully executed by an authorized representative for the Exhibitor and Exposition Manager.

Exhibitor _____

Date _____

World of Possibilities Expos 2025

Western Maryland Region, Frederick, MD



Exhibitor Name (Note: Name listed here will be used for your booth sign, website and directory listings)

Contact _____ Title _____

Mailing Address _____

City _____ State _____ Zip _____

Billing Name & Address (If different) _____

Phone _____ Fax _____

Email _____ Website _____

APPROVAL
(FOR OFFICE USE ONLY)

Date _____

Booth # _____

EXHIBIT SPACE PRICING: (All spaces include 6' table & two chairs, exhibit sign)
DOUBLE YOUR EXPOSURE: Multiple Spaces or Multiple Expos Deduct 5%

Choose Expo	Standard Space H and K Spaces	Promotional Partner Package*	Category J Spaces Oversized	Corner Space Additional
Western Maryland Region May 17, 2025	<input type="checkbox"/> \$595	Call for more information	<input type="checkbox"/> \$625	<input type="checkbox"/> \$50

***Promotional Partner Package:** Contingent upon approval as a Promotional Partner with signed Partnership Agreement (Promotional Partners agree to help promote the Expo to their contacts within the disabilities community).

† **Electric** MAY NOT be available unless you reserve it in advance. **ADD ELECTRIC** \$30

Total _____

Payment Options: (Please Check One)

TERMS: A 33% deposit must accompany this contract. Booth space cannot be reserved without a deposit. Balance is due 60 days prior to the start of each event. Failure to pay the balance when due may result in cancellation, relocation, or forfeiture.

- Check:** Make Check Payable To: **Caring Communities, Inc.**
- Credit Card:** VISA MC AMEX DISC
 Card # _____
 Name on Card _____ Exp. Date _____
 Security Code # (on back of card) _____
 Billing address of credit card: Same as above
 Different Billing Address: _____

Pay Online: Please provide me a payment link.
 Billing email: _____

The undersigned ("Exhibitor"), as a duly authorized representative, enters into an agreement with Caring Communities, the Exposition Manager, to rent exhibit space at the expositions indicated above. Space will be assigned by Caring Communities at its sole discretion and may be changed for the benefit of the exposition. Exhibitor agrees to abide by official Exhibitor Regulations (see other side of this agreement) and by the following **Cancellation Policy:** If Exhibitor desires to cancel all or part of the exhibit space, the Exhibitor acknowledges that the **Producer** would be harmed and suffer loss, but that the precise value of that harm would be difficult to calculate. Therefore any payment required herein shall be considered reasonable pre-agreed liquidated damages and not a penalty. **All cancellations, withdrawals, or reductions in space by Exhibitor must be in**

Exhibitor _____

SPACE PREFERENCES

I would prefer **NOT** to be located near the following companies:

Describe your display _____

FREE 25-Word Company Description for Expo Program Guide:

Return Form To:

CARING COMMUNITIES
 1341 West Liberty Rd.
 Sykesville, Maryland 21784
 accounts@caringcommunities.org

Office: 410-549-5707
 Sales: 443-622-5983
 Fax: 410-549-6467

writing, by certified mail, return receipt requested. Requests for cancellation made up to 90 days prior to the start of the event are subject to a fee equal to 33% of the total booth space fee; from 89 days or less prior to the start of the event, Exhibitor is subject to a fee equal to 100% of the total booth space fee. If Exhibitor defaults in payment, Exhibitor is liable to Caring Communities for collection costs, including reasonable attorney's fees. Caring Communities reserves the right to accept or reject exhibitor space applications and to cancel any previously accepted exhibitor space applications or contracts, at any time in its sole discretion, for any reason, or no reason, without liability to the applicant, exhibitor or any other third party. This contract is not valid until said contract is fully executed by an authorized representative for the Exhibitor and Exposition Manager.

Date _____

World of Possibilities Expo 2025

Presented by Caring Communities, Inc.



1. **DEFINITIONS.** "Exhibitor" means the applicant identified on the front of this form; "Exposition Manager" means Caring Communities; "Producer" means Caring Communities, Inc.; "Hall" means the facility in which the event is conducted; "Hall Management" means the owner and/or manager of the Hall, including its employees and agents; "Show", "Expo" and "Event" are used interchangeably to refer to World of Possibilities Disabilities Expo.

2. **AGREEMENT.** Exposition Manager reserves the right to decline, expel, or prohibit any exhibit, display or feature which it deems inappropriate or out of character with the show. This application, when properly executed by Exhibitor and approved by Exposition Manager, constitutes a legally binding license agreement. These Exhibit Regulations, as well as any Additional Terms and Conditions, the service manual issued by the Hall Management, rules and conditions issued by the decorator, and further rules which may be adopted by the Exposition Manager for the general success of the event are also considered binding upon the Exhibitor. This Agreement is governed by Maryland law and shall be considered entered into in the State of Maryland. The Producer makes no warranty or representations regarding the number of persons who will attend the event, such number being impossible to predict at this time. Estimates are based on attendance at similar shows and are for planning purposes only. The provisions of this contract are considered severable, such that, if any one provision of this Agreement is found by a court to be unenforceable, the remainder of this Agreement will continue in full force and effect.

3. **DESCRIPTION OF SPACE.** A standard space includes the floor space specified on the floor plan, a 6' skirted table, two chairs, and standard identification sign. Additional tables, chairs and other services will be available at an extra charge (see paragraph 12). Rental fee also includes listing in the show program directory and on the website. Exhibitor agrees that Exposition Manager and Producer will not be liable for errors and omissions in these media. Electric is NOT INCLUDED unless requested on the application prior to the event date.

4. **EXHIBIT REGULATIONS**

A. **ARRANGEMENT.** Exhibit shall be so arranged as not to obstruct the general view nor hide the other exhibits. No exhibits will be permitted to interfere with the use of other exhibits or impede access to them or free use of aisles. Plans for specially built displays not in accordance with regulations should be submitted in writing to Exposition Manager before construction is ordered. All construction shall be neat and professional.

B. **EXHIBIT DIMENSIONS.** Exhibits must stay within the dimensions of the booth and may not infringe on the aisles or other rented spaces. This is important to comply with fire regulations as well as the safety and comfort of attendees and other Exhibitors and will be strictly enforced. All demonstrations must be located so that assembled crowds, taking into account space need for wheelchairs and other equipment, are located within the Exhibitor's space and not blocking any aisle or neighboring exhibit. Back walls including signs may not exceed 8' in height. If a constructed display fails to meet these requirements, Exposition Manager reserves the right to authorize removal, relocation or alteration of the display at the sole expense of the Exhibitor.

C. **USE OF SPACE.** A description of the display construction, a list of exactly what products will be displayed, and a statement of whether direct over-the-counter cash sales will be conducted, must be submitted to the Exposition Manager no later than 30 days before the opening date of the event. The Exposition Manager will advise exhibitors about the need for appropriate temporary license and sales tax procedures. Exhibitor is responsible for collecting and remitting taxes in accordance with federal, state, and local requirements. Exhibitors shall only display merchandise as listed to the Exposition Manager and only if that merchandise is part of the product line in his ongoing course of business. Any substantial change in the type or character of Exhibitor's product line shall require written permission from the Exposition Manager. Exposition Manager reserves the right to prohibit the display of any product or signage that it deems inappropriate or out of character with the show. No representations are made herein regarding exclusivity of any merchandise or service.

D. **PROHIBITED USE.** (1) Circulars, advertising matter, etc., may be distributed and patronage solicited only within the space assigned to the Exhibitor presenting the material. (2) Exhibit space may not be occupied or shared by any firm other than that firm which originally contracted for said space. (3) Nothing will be used, including balloons, within the Hall that will injure, mar, or in any manner deface any surface of the said centers or any equipment contained herein. Balloons and neon or other gas signs are prohibited. Any device employing microwaves is prohibited, in order to protect the safety of attendees with pacemakers and similar devices. The Exhibitor, its agents, members, or guests shall not attach nails, hooks, tacks, or screws into any part of the surfaces of the Hall. The Exhibitor shall not make or allow to be made any alterations of any kind to said Hall or equipment contained herein, and will not affix or permit to be affixed on any surface, adhesives, tapes, signs, posters, notices, or graphics of any description. The surfaces shall include but not be limited to glass doors, meeting room doors, columns, walls, ceiling, floors, windows, elevators, and bathroom areas. Painting of any kind is prohibited. If the premises are defaced or damaged by an act of negligence by any Exhibitor, its agents, or guests, the Exhibitor will pay the sum deemed necessary for complete restoration to the previous conditions. (4) Exhibits must remain intact, open and staffed until the official closing hour of the exhibit hall. Dismantling begins at 3:00 pm on Saturday and must be completed by 5:00 pm Saturday. (5) Exhibitors shall not use any music from any source which requires the permission of the copyright owner unless they have obtained in advance a license to perform such music, paid any fees required, and provided the Exposition Manager with a copy of the fully executed license Agreement. Exhibitor agrees to indemnify Producer, Exposition Manager, and Hall Management for all claims resulting from failure to comply with these requirements. Sound systems may be used provided that they are not audible more than three feet into the aisle or into neighboring exhibit spaces. The Exhibit Manager reserves the right to control any sounds it deems objectionable. (6) Exhibitor shall not make any promotional efforts, or provide transportation, that has the effect of drawing attendees away from the main show area, except as allowed by the Exposition Manager in regard to authorized workshops, demonstrations, and displays. (7) All food is prohibited at Exhibitor's space, except complementary candy, without written permission from the Exposition Manager.

E. **EXHIBITOR'S REPRESENTATIVE.** The Exhibitor will name ONE individual as its duly authorized representative, to have charge, and hereby accepts and assumes responsibility for such representative, or alternates, being in attendance at its exhibit throughout exhibit periods.

5. **EXHIBIT RESERVATION, PAYMENT, & CANCELLATION.** Reservations will be made with a 33% booth deposit for each space requested. If Exhibitor's booth preferences are not made available, space will be assigned which is most similar to the Exhibitor's first choice in location, price, and competitive situation. Booth assignment responsibility rests with the Exposition Manager, who also reserves the right to change Exhibitor's space assignment after acceptance of this Agreement if it is deemed in the best interest of the show. Exposition Manager will make every reasonable effort, in this event, to ensure that the reassignment is in the same general nature and style of the original space. The exhibit balance is due in full within 90 days of the start of the event. If the balance is not received by that date, the Producer may resell, reassign, or reuse the space. If Exhibitor desires to cancel all or part of the exhibit space, the Exhibitor acknowledges that the Producer would be harmed and suffer loss, but that the precise value of that harm would be difficult to calculate. Therefore any payment required here-in shall be considered reasonable pre-agreed liquidated damages and not a penalty. **All cancellations, withdrawals, or reductions in space by Exhibitor must be in writing, by certified mail, return receipt requested.** Requests for cancellation made up to 90 days prior to the start of the event are subject to a fee equal to 33% of the total booth space fee; from 89 days or less prior to the start of the event, Exhibitor is subject to a fee equal to 100% of the total booth space fee. This fee is calculated based on the date the event is scheduled to start, regardless of when the contract was executed. If Exhibitor defaults in payment, Exhibitor is liable to Exposition Manager for the entire amount owed plus collection costs, including reasonable attorney's fees. No Exhibitor will be permitted to erect a display space until space rental is paid in full. Make checks payable to Caring Communities, Inc. If Exhibitor defaults, Exposition Manager may assign or rent the space again with no rebate or allowance due to the Exhibitor, and without releasing Exhibitor from his obligations. Downgrading (cancelling a portion of the previously rented space) is subject to a \$100 per booth administration fee up to 30 days before the start of the event, after which the fee is equal to 33% of the total booth fee.

6. **FAILURE TO OCCUPY SPACE.** Any space not occupied by 10:30 am on the day of the event is scheduled to open, or any space vacated at any time during published show times, will be forfeited by Exhibitor and its space resold, reassigned, or used by Exhibit Manager without refund of rental price. If a crated, constructed display is not set up by 9:00 am on the day the event starts, it is agreed that Exposition Manager reserves the right to authorize setup, which service will be charged to the Exhibitor, who agrees to a full release of liability to all parties. It is mutually agreed that it is the duty and responsibility of each Exhibitor to install its exhibit before the opening of the Expo and to dismantle its exhibit immediately after the close of the Expo.

7. **CANCELLATION OF EXPOSITION.** In the event of cancellation or postponement of the Expo due to fire, strikes, government relations, terrorist acts, or other causes beyond the control of the Producer, Producer will refund as large a portion of the exhibit fee as it deems consistent with the expenditures and commitments already made.

8. **INSURANCE.** Exhibitor shall provide verification of insurance coverage at least 30 days before the start of the event. The Certificate of Insurance shall indicate: (a) Broad Form Public Liability Insurance with a minimum of \$1,000,000 combined single limit per occurrence, (b) name Caring Communities, Inc. as additional insured, and (c) list the insurance agency issuing the certificate. In addition, Exhibitors wishing to insure their exhibits, displays and merchandise against fire, theft, etc. must do so at their own expense.

9. **LIABILITY.** The Exhibitor is entirely responsible for the space leased and has the sole responsibility of keeping said space free from any conditions dangerous to persons visiting or working the exhibition floor. Exhibitor agrees to hold Producer, Exhibition Manager, Hall Manager, and their employees, agents and partners harmless from any and all claims and expenses for any injury, loss, or damage that may occur to Exhibitor, or to Exhibitor's employees, guests, or property from any cause whatsoever, as a result of the use of the rented space, or the actions or failure to act of any party associated with the Exhibitor, and agrees to indemnify the above parties from all such claims. In no event shall Producer or any of its affiliates be held liable for any damages arising out of or in connection with this Agreement. Exhibitor recognizes that no other party holds insurance that relieves him from liability of damages as a result of use of the rented space. Exhibitor is solely responsible for damages to the premises and for violation of any law, code or regulation. Liability for any condition shall not be limited to insurance coverage limits stated in Paragraph 8.

10. **FIRE, SAFETY, & HEALTH.** Exhibitor assumes all responsibility for compliance with all federal, state, local and provincial regulations and ordinances, including those covering fire, safety, and health. All exhibit equipment and materials shall be located within the booth and be protected by safety guards and devices where necessary. Only fire-proof materials may be used in displays and necessary fire precautions shall be taken by the Exhibitor. Exposition Manager reserves the right to prohibit or cause removal of any exhibit or display or feature thereof if it is deemed to present a hazard of any kind, exceeds the allowed size or weight, or fails to comply with any applicable law, code or regulation.

11. **SECURITY.** Exhibitor agrees that Exposition Manager, Producer and Hall Manager are not responsible for anything its guard service does or fails to do, including loss to the Exhibitor and its representatives. Exhibitor will not be allowed in the exhibit area after show hours. Exhibitor may want to consider arranging security for its exhibit space either during or after show hours.

12. **AVAILABLE SERVICES.** On behalf of Exhibitors, Exposition Manager has designated official show contractors to provide services such as drayage, cartage, furniture, booth and floor decorations, signs, telephone, internet services, etc. Arrangement of these services is between Exhibitor and show contractor. Call Caring Communities at 410-549-5707 for more information.

MOVE IN
Heavy freight & Booth displays:
8:00-10:30 am
Call For details

SHOW HOURS
11:00 am to 3:00 pm

MOVE OUT
3:00 pm - 5:00 pm
**All exhibits *must* be removed
from the exhibit area by 5:00 pm**

World of Possibilities Expos 2025

Presented by Caring Communities, Inc.

Increase Your **EXPO**sure



ONSITE PROMOTION

PROMOTIONAL VIDEO SHOWN CONTINUOUSLY IN HALLWAY AND EXHIBIT HALL (COLLEGE PARK ONLY)

Your 30-second video run continuously on monitors in the Hallway and Main Exhibit Hall. With sound, although captions are highly recommended. Customer provides finished video in mp4 format.

- \$249 Exhibitors
- \$499 Non-Exhibitors

PROMOTIONAL MATERIAL DISTRIBUTION AT ENTRANCE TO EXHIBIT HALL

Have one promotional giveaway item (bookmark, pen, notepad) inserted into every Expo bag. A great way to ensure your message is seen! Note: Items thicker than 1" not available for Expo bag placement.

- \$150 Exhibitors
- \$395 Non-Exhibitors

PRODUCT DEMONSTRATION/ INFORMATION SESSION

Demonstrate your latest products or services to a captive audience in a 20 minute session conducted in a private workshop room. Advertised on the website, in the Main lobby and in the Expo Program Guide. (Note: Space limited to 4 presenters).

- \$150 per session

ON-SITE SIGNAGE

Display your message to attendees in the common areas of the exhibit hall. (*Exhibitor is responsible for cost of production.*)

- Starting at \$200, depending on location.

OTHER PROMOTIONAL OPPORTUNITIES

Call for details and pricing:

- Wheelchair Service Sponsorship
- Personal Care Assistant Sponsorship
- Sign Language Interpreter Sponsorship
- Entertainment Sponsorship
- Your idea!

CARING COMMUNITIES
 1341 West Liberty Rd.
 Sykesville, Maryland 21784
accounts@caringcommunities.org
 Office: 410-549-5707
 Sales: 443-622-5983
 Fax: 410-549-6467
caringcommunities.org

Nation's Capital Region
 Samuel Riggs IV Alumni Center
 COLLEGE PARK, MARYLAND
MAY 3, 2025

Western Maryland Region
 Clarion Inn Frederick Event Center
 FREDERICK, MARYLAND
MAY 17, 2025

BILLING INFORMATION

COMPANY _____

AGENCY (if applicable) _____

CONTACT PERSON _____

BILLING ADDRESS _____

PHONE _____

FAX _____

E-MAIL _____

P.O. NUMBER _____

TERMS: Payment in full due 30 days before start of event.

Total \$ _____

Payment Options: (Please Check One)

Check: Make Check Payable To: **Caring Communities, Inc.**

Credit Card: VISA MC AMEX DISC

Card # _____

Name on Card _____ Exp. Date _____

Security Code # (on back of card) _____

Billing address of credit card: Same as above

Different Billing Address: _____

Pay Online: Please provide me a payment link.

Billing email: _____

Signature _____ Title _____ Date _____

World of Possibilities Expos 2025

Presented by Caring Communities, Inc.



ADVERTISE IN THE EXPO PROGRAM BOOKLET

Increase your visibility, attract visitors to your booth, and help attendees remember you.

DISPLAY AD RATES:

Rates are net and non-commissionable.

Expo Ad Deadline: three weeks prior to Expo

Black & White Rates:

- Full Page-Full Color (Quantity limited).....\$250
- Full Page-Black and White\$185
- Half Page\$100

Note: Sorry, Quarter page ads are no longer available

Email ads to accounts@caringcommunities.org

Nation's Capital Region
Samuel Riggs IV Alumni Center
COLLEGE PARK, MARYLAND
MAY 3, 2025

Western Maryland Region
Clarion Inn Frederick Event Center
FREDERICK, MARYLAND
MAY 17, 2025



COMPANY _____

AGENCY (if applicable) _____

CONTACT PERSON _____

BILLING ADDRESS _____

PHONE _____

FAX _____

E-MAIL _____

P.O. NUMBER _____

Total \$ _____

Payment Options: (Please Check One)

Check: Make Check Payable To: **Caring Communities, Inc.**

Credit Card: VISA MC AMEX DISC

Card # _____

Name on Card _____ Exp. Date _____

Security Code # (on back of card) _____

Billing address of credit card: Same as above

Different Billing Address: _____

Pay Online: Please provide me a payment link.

Billing email: _____

Signature _____ Title _____ Date _____

EXPO PROGRAM

MECHANICAL SPECIFICATIONS

ELECTRONIC FORMAT

All ads are accepted in electronic formats only.

- Type of files accepted:

TIFF – Save all photos in 300 dpi, line art in 600 dpi.

EPS – Include all embedded files and fonts.

PDF – Use Acrobat 8.0 compatibility, save grayscale and color images at 300 dpi, Embed all fonts.

No color management.

JPG – Avoid this file type if possible, save as 350 dpi when unavoidable.

NOTE: Customer is responsible for quality of all files submitted.

- Save all black and white files in GRAYSCALE, not in color.

Save all color files in CMYK, avoid oversaturated black (No greater than 300% color saturation).

- Newspaper and magazine art and photos are not acceptable for reproduction.

HARD COPIES & PICTURES

Not accepted; All ads must be submitted as electronic images.

AD SIZES (without bleed)

Full Page: 4 3/4" W by 7 3/4" H

Half Page: 4 3/4" W by 3 5/8" H

AD SIZES (with bleed)

Full Page: 5 3/4" W by 8 3/4" H

(Live image such as text to stay inside 5 1/4" x 8 1/4")

PLACEMENT:

Placement is limited to Publisher's choice. Requests for placement preferences will be considered on a first-come, first-served basis, subject to the discretion of the Publisher.

World Of Possibilities Expo - Nations's Capital Region
May 3, 2025

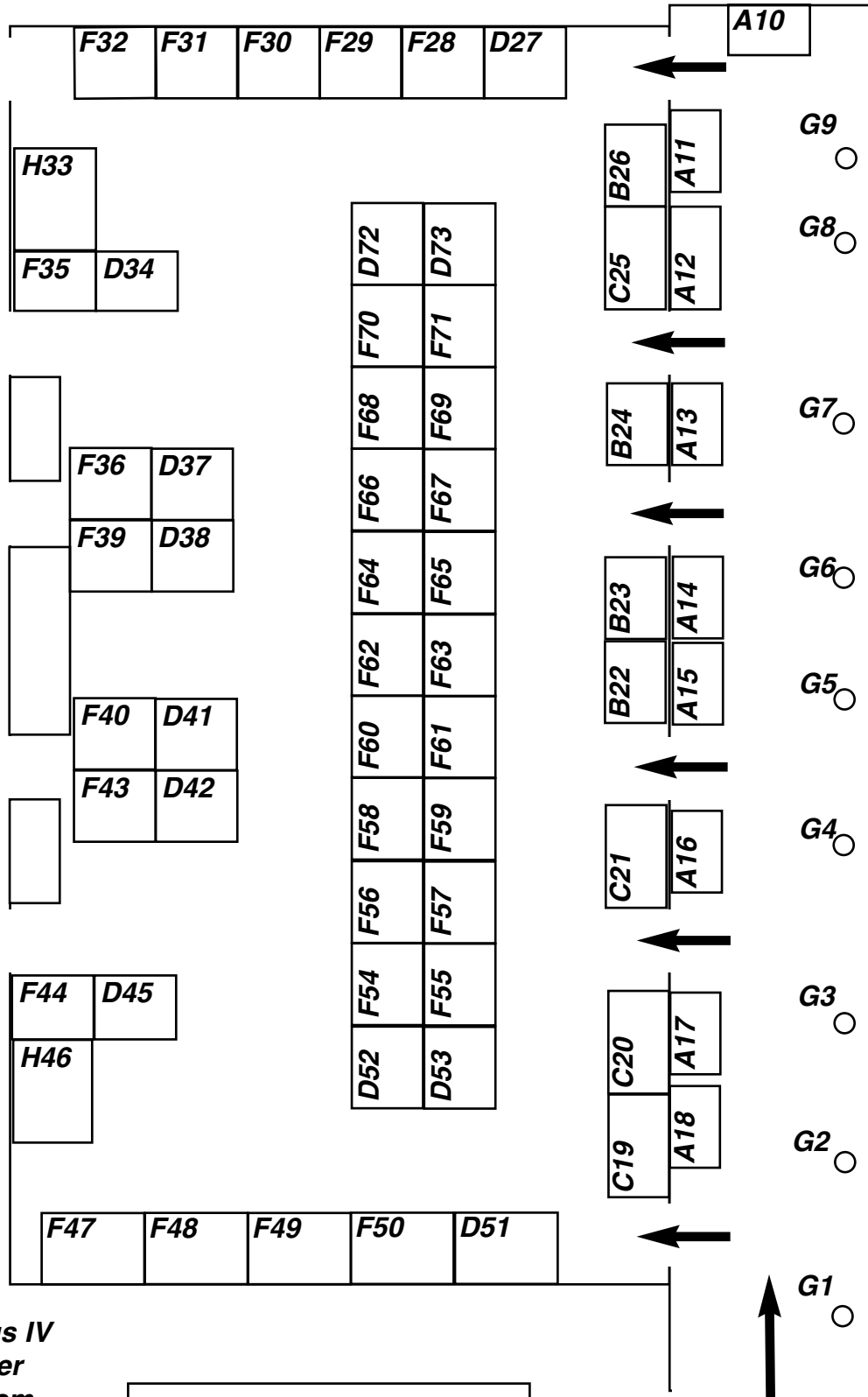

A=8' x 5'
 B=8' x 6'
 C=10' x 6'
 D=8' x 7'
 F=8' x 7'
 G=28" Dia.
 High Top
 H=10' x 8'

**Samuel Riggs IV
 Alumni Center
 Orem Ballroom**

Maryland Club

**Rotunda
 (Spaces B74-B81)**

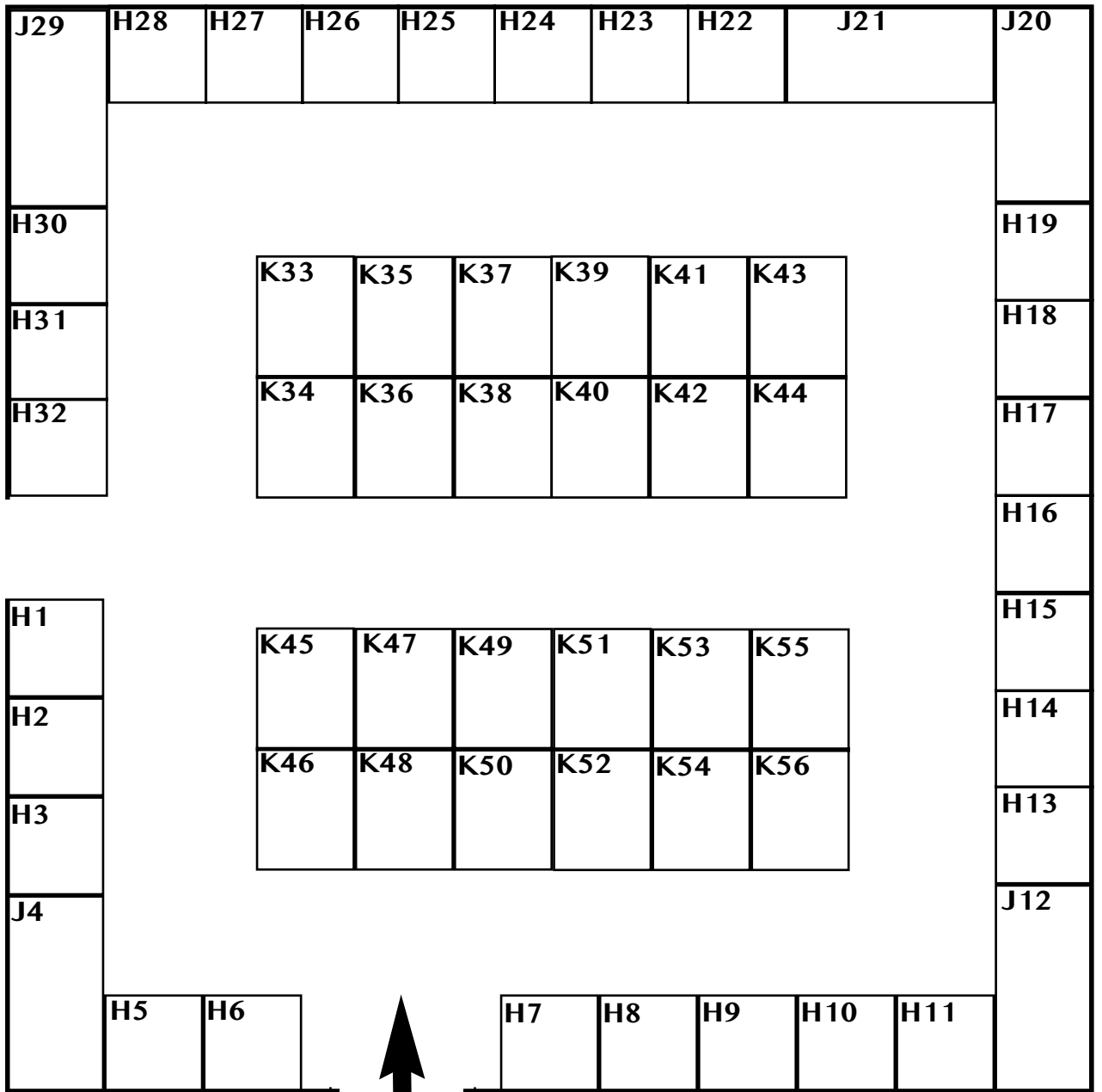

World of Possibilities Expo
Clarion Inn Event Ctr.
Frederick, MD
May 17, 2025

Francis Scott Key
Ballroom and Lobby

Registration

Banquet Entrance

Lobby Entrance

H=8 x8'
 J=8'x15'
 K=8'x10'

